

DC Axial Fan / 6CM



Model No.

X0602512Y 60x60x25mm

Frame and Impeller Material :
Plastic (UL 94V-O)

Bearing system :
Ball Bearing (B)
Sleeve Bearing (S)
Duro Bearing (DS)

Lead Wires :
UL 1007 AWG 28 or equivalent.
Red:+, Black:-

Model No. :
X0602512Y

X=Bearing System, can be B, S or DS type..
Y=Fan speed, can be L, M or H.

Net Weight :
52g



OUTLINE

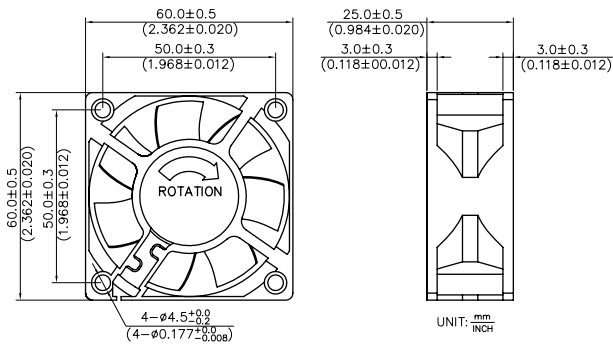

CHARACTERISTIC CURVES

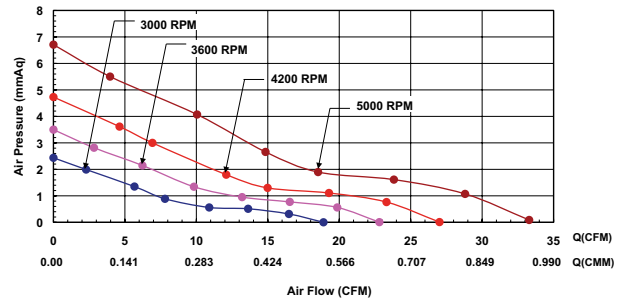

SPECIFICATIONS

Item Model No.	Operating Voltage Range	Rated Voltage	Rated Current	Rated Input Power	Speed	Max Air Flow		Max Air Pressure		Noise
	V _{DC}	V	Amp	Watt	R.P.M	m ³ /min	CFM	mmH ₂ O	inH ₂ O	dBA
B/FDB/S0602512L	6~13.8	12	0.12	1.44	3000	0.54	18.90	2.44	0.10	22.1
B/FDB/S0602512M	6~13.8	12	0.15	1.80	3600	0.65	22.81	3.50	0.14	26.1
B/FDB/S0602512H	6~13.8	12	0.17	2.04	4200	0.77	27.02	4.73	0.19	30.4
B/FDB/S0602512HH	6~13.8	12	0.22	2.64	5000	0.94	33.29	6.71	0.26	35.5
DS0602512LL	6~13.8	12	0.10	1.20	2400	0.46	16.07	1.82	0.07	12.8
DS0602512L	6~13.8	12	0.12	1.44	3000	0.54	19.08	2.73	0.11	18.9