

DC Axial Fan / 12CM



Model No.

X1202512Y 120x120x25mm

Frame and Impeller Material :
Plastic (UL 94V-O)

Bearing system :
Ball Bearing (B)
Sleeve Bearing (S)
Duro Bearing (DS)
Fluid Dynamic Bearing (FDB)

Lead Wires :
UL 1007 AWG 28 or equivalent.
Red:+, Black:-

Model No. :
X1202512Y

X=Bearing System, can be B, S, DS or FDB type..

Y=Fan speed, can be L, M or H.

Net Weight :
134g

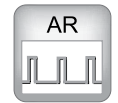

OUTLINE

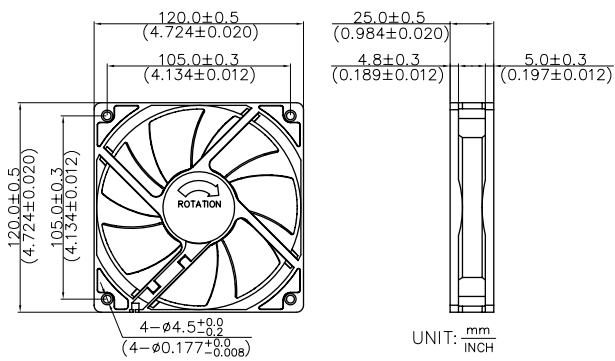

CHARACTERISTIC CURVES

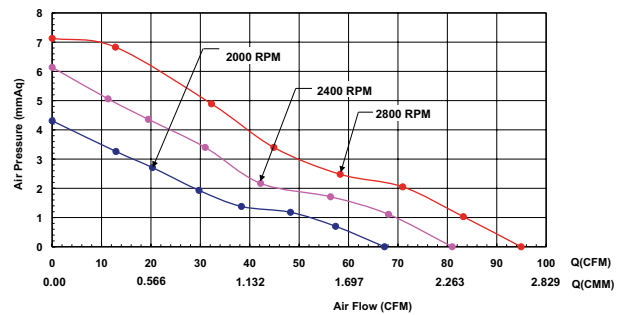

SPECIFICATIONS

Item	Operating Voltage Range	Rated Voltage	Rated Current	Rated Input Power	Speed	Max Air Flow		Max Air Pressure		Noise
	V _{DC}	V	Amp	Watt	R.P.M	m ³ /min	CFM	mmH ₂ O	inH ₂ O	dBA
Model No. B/FDB/S1202512L	6~13.8	12	0.18	2.16	2000	2.57	90.92	3.06	0.12	34.0
B/FDB/S1202512M	6~13.8	12	0.30	3.60	2400	2.92	103.26	4.23	0.17	39.0
B/FDB/S1202512H	3.5~13.8	12	0.52	6.24	2800	3.51	124.11	5.79	0.23	43.6